

Model FL8-A Portable Cable Fault Locator



Clinton Instrument Company

295 East Main Street
Clinton, CT 06413 USA
Telephone: 860.669.7548 Fax: 860.669.3825
www.clintoninstrument.com

Contents

SPECIFICATIONS	5
SAFETY	7
DANGER! HIGH VOLTAGE SAFETY HAZARDS.....	7
A WARNING TO SUPERVISORS!	7
A WARNING NOTE TO OPERATORS!.....	7
HIGH VOLTAGE FACTS	8
SAFETY SYMBOL	8
ENVIRONMENTAL CONDITIONS.....	8
INSTALLATION	10
UNPACKING.....	10
PASSWORD PROTECTION.....	10
DEFINITIONS.....	11
SHORTS.....	11
<i>Metallic Short</i>	11
<i>High Voltage Short</i>	11
<i>Intermittent Arc</i>	11
OPENS.....	11
HI-POT TEST	11
LOOP RESISTANCE.....	11
ACCURACY	11
<i>Low</i>	12
<i>Standard</i>	12
<i>Exceptional</i>	12
FL-8A CONTROLS	13
<i>ON/OFF Power Switch</i>	13
<i>Front Panel touch screen</i>	13
<i>Safety buttons</i>	13
<i>Red and blue test probes</i>	13
<i>Green ground probe</i>	13
<i>Indicator Lights</i>	13
SETTING MENU.....	14
GLOBAL SETTINGS.....	14
<i>Calibration</i>	14
<i>Language</i>	14
<i>Unit of Measure</i>	15
<i>System Information</i>	15
<i>System Errors</i>	15
<i>Set System Defaults</i>	15
<i>Set Admin Password</i>	15
<i>Lock Settings Menu</i>	15
<i>Set Date and Time</i>	15
SHORTS PARAMETERS	16
<i>Auto Voltage Detect</i>	16
<i>Full Test</i>	16
<i>Lock Test Voltage</i>	16

<i>Shorts Max Voltage</i>	17
OPENS PARAMETERS	17
<i>Auto Frequency Select</i>	17
<i>Full Test</i>	17
<i>Lock Test Frequency</i>	18
<i>Opens Start Frequency</i>	18
HI-POT PARAMETERS.....	18
<i>Lock Hi-Pot Settings</i>	18
<i>Vmax (kV)</i>	18
<i>Vsteps (#)</i>	18
<i>Vramp Time (s)</i>	18
<i>Vhold Time (s)</i>	18
TESTING LARGE CABLES WITH THE FL-8A	19
PERFORMING A SHORTS TEST	20
PERFORMING AN OPEN TESTS	22
PERFORMING A HI-POT TEST	23
CALIBRATION	26
CALIBRATE THE FL-8A OUTPUT VOLTAGE	26
CALIBRATE THE FL-8A VOLTAGE READING	27
MAINTENANCE	28
FUSES	28
BATTERY.....	28
HOW TO USE THE 91785 FL TEST BOX	29
DESCRIPTION	29
TYPE OF CABLE FAULTS.....	29
TESTING WITH THE FL TEST BOX.....	29
<i>Testing for Opens Accuracy</i>	29
<i>Testing for Metallic Shorts Accuracy</i>	30
<i>Testing for High Voltage Shorts Accuracy</i>	30
TROUBLESHOOTING	33
REPLACEMENT PARTS	34
OPTIONAL ACCESSORIES	34
ELECTRIC SHOCK CONSIDERATIONS FOR ELECTRIC VEHICLE CHARGING SYSTEMS	35
ELECTRIC SHOCK- WHAT IS IT?.....	35
PERCEPTION AND STARTLE REACTION	35
MUSCLE TENTANIZATION	36
VENTRICULAR FILBRILLATION	36
BURNS	37
GROUNDING.....	37
DOUBLE INSULATION.....	37
GROUND FAULT CIRCUIT INTERRUPTER	38
SHIELDING.....	38
POLARIZATION	39
INTERLOCKS AND “SMART” CIRCUITS.....	39

WARRANTY41

Specifications

MODEL FL-8A

Portable Cable Fault Locator

- >> Battery operated cable fault locator
- >> Quickly locates opens, shorts and high voltage shorts in cable lengths
- >> Robust design for harsh environments
- >> Fully automated testing
- >> Color touch screen



Long lengths of cable used in land drilling, offshore well development and production, marine and ROV applications are routinely subject to mechanical shock as well as electrical and thermal stress. Damage to these multi-conductor constructions, which may contain crucial power, control signal and video conductors, can result in down time and costly cable replacement.

To meet the needs of these applications, Clinton has developed the Model FL-8A, a battery operated cable fault locator that can be used on site to accurately pinpoint opens and shorts in these cables. Built to withstand a demanding environment, the unit performs a quick, automated test.

The operator simply connects the FL-8A test probes to each end of the damaged cable, enters the cable length on the digital touch screen, and selects "Shorts" or "Opens" to begin the test. The unit quickly calculates the distance of the fault site from each test probe, displays the location in feet or meters, and provides a suggested trim area. The failure can then be cut out or repaired and the remaining good product reused. Many times, most of the cable can be recovered and

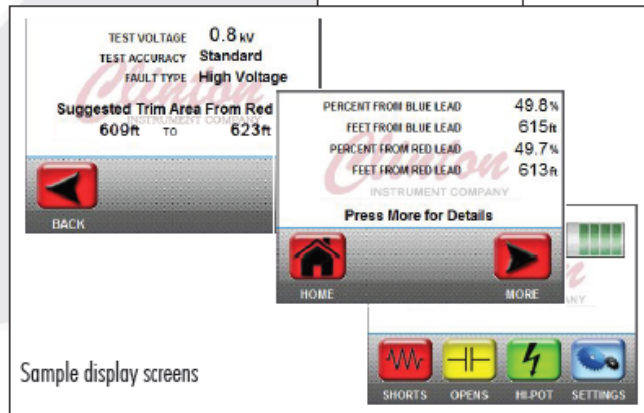

Sample display screens

put back into service.

The FL-8A Cable Fault Locator is a compact 43 lbs. built into a sturdy wheeled case. It promises a great return on investment by analyzing expensive cable assemblies with speed and accuracy.



FL-8A SPECIFICATIONS

Fault Definitions:

- Open.....A condition where a single conductor has no continuity from one end to the other.
- Metallic Short.....Two conductors without insulation or a conductor and a shield which physically come into contact with one another.
- High Voltage Short.....Two conductors or a conductor and a shield which have no insulation between them but do not contact one another.
- Voltage Test Range.....0-8 KV D.C.
- Display.....6-inch backlit color TFT touch screen.
- Output Current.....6 ma. maximum.

- Equipment Accuracy.....Better than 1% of total cable length (dependent on accuracy of actual cable footage and product uniformity).
- Cable Loop Resistance
 - Metallic Short.....50 milliohms minimum.
 - High Voltage Short.....300 milliohms minimum.
- Dimensions.....22.0"W x 18.2"D x 10.4"H.
- Test Leads.....10' long.
- Weight.....43 lbs. (19.5 kg.).
- Battery Power.....Ni-MH 24V 5Ah, rechargeable through FL-8A power cord.
- Recharge Power.....100 - 240 volts AC, 50/60 Hz 2 amps.

FL-8A Dimensions

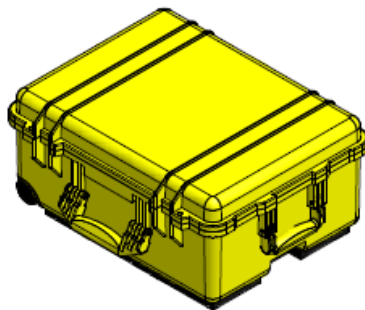
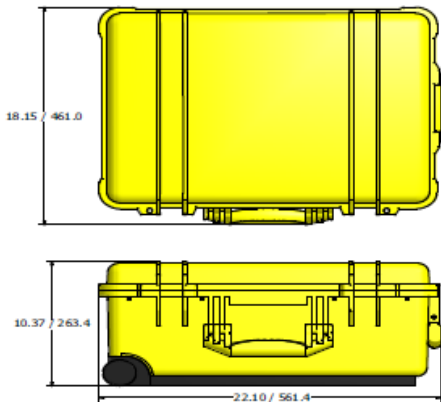

Typical Lead Connections

Shorts

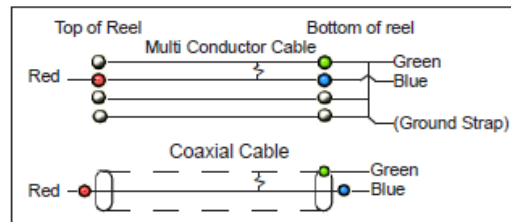

Opens

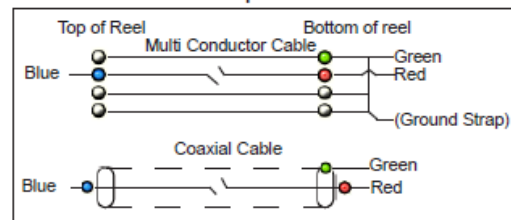

Safety

Danger! High Voltage Safety Hazards

Caution—Read before using this equipment.



DISCHARGE ALL CONDUCTORS OF THE TEST CABLE PRIOR TO CONNECTING TO THE FL-8A. YOU MUST REMOVE ANY STORED CHARGE FROM THE PREVIOUS OPERATION, SUCH AS A HI-POT TEST. A STORED CHARGE IN THE CABLE CAN KILL!

The FL-8A employs high voltage to locate cable faults. It is imperative that only personnel trained in the dangers of high voltage operate this equipment. **A stored charge in the TEST PRODUCT can be lethal**, even when the cable is no longer attached to the FL-8A. Please read and understand the manual prior to operating this equipment.

A Warning to Supervisors!



The FL-8A is equipped with such safety features as external and internal safety interlocks, a red high voltage warning light, grounding sensors, and password protection. Do not attempt to defeat or bypass any safety feature. Failure to observe proper safety precautions can result in severe injury or death!

Supervisory personnel are strongly advised to use the built-in password protection feature to prevent unauthorized persons from defeating safety features or changing test parameters. Read the section in Installation entitled, "Password Protection," for further information.

A Warning Note to Operators!



When cables are being tested with this or any high voltage equipment, the possibility of leaving a dangerous charge in the cable is always present. Always bunch together and ground all conductors not under test, including to the cable shield and to the earth ground, using the provided ground probe. Make sure the test is complete, that the high voltage indicator lamp is off, and all leads are shorted to ground before touching part of the cables.

Although the high voltage output of the FL-8A is not in itself capable of delivering a truly dangerous shock, a stored charge in the cable can, if proper safety precautions are not taken. For this reason, operators and supervisors should establish rigid safety procedures for the use of this and all high voltage equipment.

High Voltage Facts

The commonly accepted maximum values of 60Hz. Current passing through the human adult body which permit a subject to let go of electrodes are nine milliamperes for females. At 3000Hz. this value increases to about 22 milliamperes for men or 15 milliamperes for women. DC currents do not present the same let go problems, but a subject can readily let go at a level of 60 milliamperes. A continuous 60Hz. current above 18 milliamperes stops breathing for the duration of the shock only. Ventricular fibrillation may occur above a level of 67 milliamperes. The reaction current level of 60Hz. is about .5 milliamperes. Above this level a muscular reaction can occur which can cause a secondary accident. The DC and 3 kHz. Levels are probably considerably higher.

Capacitor discharge energy of 50 Joules (watts-seconds) is regarded as hazardous.

For references, see: Dalziel, Ogden, Abbot, "Effect of Frequency on Let-Go Currents," Transactions of A.I.E.E., Volume 62, December 1943, and Dalziel, "Electric Shock Hazard," I.E.E.E., Spectrum, February 1972.

Safety Symbol

The symbols depicted below are safety symbols placed on spark test equipment. It is important to understand the meaning of each.



Caution symbol. Caution- refer to the manual to protect against damage to the equipment or to avoid personal injury.



Risk of electric shock symbol.



Earth ground symbol.

Environmental Conditions

The spark tester is designed to be safe under the following conditions:

- Indoor use.
- Altitude to 2000m.
- Temperatures from 5°C to 40°C.
- Humidity to 80% R.H. at 31°C, decreasing linearly to 50% R.H. at 40°C

The Clinton Instrument Company certifies that this equipment met its published specifications at the time of shipment. The calibrations of the equipment are

checked against Measurement Standards (Reference) maintained by the Clinton Instrument Company. The accuracy of these standards is traceable to the national standards at the National Institute of Standards and Technology (NIST) or derived by ratio type measurements. For customer service or technical assistance with this equipment, please contact:

The Clinton Instrument Company
295 East Main Street, Clinton, CT 06413 USA
Telephone: 860-669-7548 Fax: 860-669-3825
Website: www.clintoninstrument.com
Email: support@clintoninstrument.com

Installation

Unpacking



The following items are included in the shipment:

- FL-8A Cable Fault Locator, with a set of 3 test probes (red, blue, and green) and power cord attached.
- 91785 FL Test Box.
- (3) 92100 Probe Clip Assemblies (other sizes available).
- An instruction manual.

Remove the FL-8A and accessories from the carton. Retain the packing material in the event that the unit is returned for calibration or service at some future time.

Password Protection



The FL-8A offers password protection that can prevent unauthorized individuals from defeating safety features and changing voltage settings and test parameters. Using password protection will make your workplace safer.

After making necessary changes in the Settings menu, go to the Set Admin Password setting. The default password is 1111. To change it, press the displayed password to access a keypad. Enter a new 4-digit password and press OK.

After entering a new password, go to the Lock Settings Menu function and turn it ON. This will restrict unauthorized personnel from accessing the Settings menu. If the new password should be lost, contact the factory.

Definitions

Shorts

Metallic Short

A condition where there is direct metal-to-metal contact between two conductors.

High Voltage Short

Two conductors without insulation, or a conductor and a shield with no insulation between them, where there is no direct contact. The condition is detected only at high voltage when arcing occurs between conductors.

Intermittent Arc

An intermittent arc is a high voltage short present that breaks down marginally at the selected hi-pot voltage.

Opens

An open is a condition where a single conductor has no continuity from one end to the other.

Hi-Pot Test

Also called a dielectric withstand test. The purpose of this test is to charge one conductor to determine if high voltage at a predetermined level will discharge to ground through the insulation. If too much current flows, the conductor is not well insulated, and it fails the test.

Loop Resistance

Conductor resistance to the flow of electrical current, measured in ohms/1,000 feet. Resistance is inversely proportional to the cross-sectional area of the conductor, so when the diameter of the conductor is doubled, the resistance declines 50 percent. FL-8A tests for metallic shorts are accurate on conductors with loop resistances of 50 milliohms or greater. Tests for high voltage shorts are effective on conductors with resistances of 200-250 milliohms or greater.

Accuracy

The accuracy of the test performed. Ratings are influenced by cable characteristics such as low loop resistance. Accuracy is reported as follows:

[Low](#)

There may be multiple faults in the cable, the cable may have low loop resistance, or the fault is judged to be close to either end.

[Standard](#)

The test is considered good, with good results.

[Exceptional](#)

The fault location was easily located, and test results are accurate within 1% of the cable length.

FL-8A Controls



ON/OFF Power Switch

This switch is located beneath the front panel touch screen.

Front Panel touch screen

The touch screen is used to set test parameters, run tests, view the battery level, and test results. Never press the touch screen with a tool or sharp object. The screen will turn OFF after a period of inactivity. Simply touch the screen to turn ON the display.

Safety buttons

Located on each side of the FL-8A front panel, the safety buttons must be held in during a shorts or hi-pot test. This is a safety feature that prevents the operator from touching the charged test cable during a test.



Red and blue test probes

The red probe will connect to one end of a test conductor, and the blue probe to the opposite end. Review the instructions in the Installation section on how to properly strip back the conductors and insert them into the probes. This is an important safety procedure.

Green ground probe

The green ground probe is used to make connections to the reference conductor and to ground the test cable. Review the instructions in the test sections on how to properly strip back the conductors and insert them into the probe. This is an important safety procedure.



Indicator Lights

The FL-8A front panel has two indicator lights. The yellow Test In Progress light will flash during a test. The red High Voltage Present light will illuminate when high voltage is present at the probes. Both lights will flash during the power up sequence.



Warning: when the red High Voltage light is illuminated, do not touch the red and blue probes or the test cable, because a charge is present. If the cable capacitance is large, the light may be illuminated for several seconds after the test is complete.

Setting Menu



Test parameters are found on the touch screen Settings menu. They are saved in memory even when the FL-8A is off. To view or change test parameters, turn on the FL-8A power switch, which is located on the back of the top panel. The FL-8A will take a few moments to boot up. Do not touch the screen until the Clinton logo appears. The main menu will appear.

Press the Setting button.



The Password Entry screen will appear. Click inside the Password box and enter the password on the keypad and press OK. The default password is 1111. Press NEXT. (If you wish to change the password, go to Set Admin Password, on a later page of the Settings menu).

The first page of the Settings menu will appear.

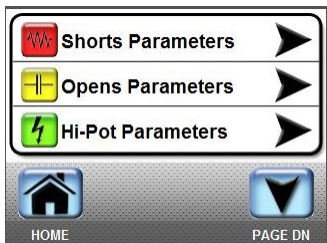

Press Pg Down to the next few pages of the Settings menu to access the following global settings: Calibration, Language, Caged Operation and Unit of Measure. These settings apply to all Opens, Shorts and Hi-Pot Testing.

Global Settings

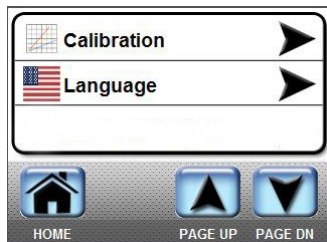

Global settings such as Calibration, Language, and Unit of Measure apply to Opens, Shorts, and Hi-Pot tests. They are found in the several pages of the Settings Menu. To view or modify a setting, press the appropriate button to access the sub screen. Additional screens such as System Information, System Errors, Set System Defaults, and Set Admin Password are also included in the Settings menu.

Calibration

This setting allows the user to calibrate the FL-8A output voltage and voltage reporting. Refer to the section entitled, "Calibration," for specific instructions.

Language



Flag icons representing the languages that are available on the FL-8A are displayed here. The languages are English, Japanese, Spanish, German, French, Italian, Swedish, and Chinese. Press the flag icon of your choice. The default setting is English.

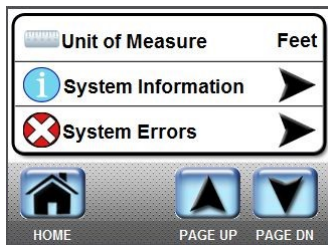

Unit of Measure

Test cable lengths may be displayed in feet or meters. The unit of measure cannot be changed during a test. Press the displayed choice to toggle between Feet or Meters.

System Information

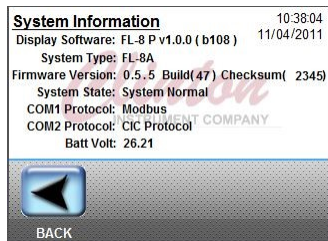

FL-8A firmware and software version numbers are stored here. During troubleshooting, you may be asked for this information by a Clinton technician.

System Errors

System error information is stored here. A Clinton technician may request that you access this information during troubleshooting if the yellow or red lights on the back of the FL-8A are flashing.

Set System Defaults



The Set System Defaults RESTORES system defaults. Restoring System Defaults does not affect calibration.

Set Admin Password

When Lock Settings is ON, a password is required to access the Settings menu. Reserving global setting access to supervisory personnel prevents unauthorized individuals from changing test parameters or defeating safety features. The default password is 1111. To change it, press the displayed password to access a keypad. Enter a new 4-digit password and press the check mark/accept button.

After changing the password, turn Locked Setting Menu ON to prevent unauthorized access to the Settings menu.

Note: change the Password before you turn ON the Lock Settings Menu option.

Lock Settings Menu



When Lock Setting Menu is ON, you will be required to enter the admin password to access the Settings menu. If the password is lost, contact the factory. The default setting is OFF.

Set Date and Time



If printed report information with date and time is required, enter the current date and time. The FL-8A will retain this setting in memory, even when it is turned OFF.

Shorts Parameters

Shorts Parameters are accessed from the Settings menu. The first page of the Shorts Parameters settings will appear. These settings will apply to all shorts tests that will be done. They are saved in memory even when the FL-8A is off.

Auto Voltage Detect

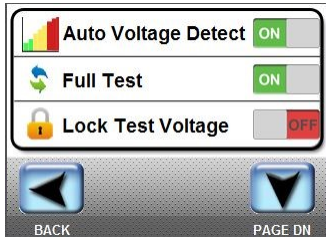

During the shorts test, the optimum voltage level is the test voltage required to cause a fault to arc to ground, not higher. When Auto Voltage Detect is ON, the fault locator will begin testing the conductor at 10% of the Shorts Max Voltage and increase it by 10% increments until a short is found. For example, if Shorts Max Voltage is set at 8KV, the test voltage begins at .8KV and rises by 1KV until a short is found.

This feature may prevent damage to the cable by testing at the lowest possible voltage. It also may be useful when multiple high voltage shorts are present, since one short may arc at a lower test voltage than another. When the first short is detected, it can be cut out of the cable, and the test can be resumed to locate the second short.

Full Test



When this setting is ON, the equipment will first locate the distance of the short from the red probe, and then find its distance from the blue probe. A summary screen showing the distance of the fault from each probe will display. The total of the two distances should equal the length of the test cable. By pressing MORE, the operator may view the rated accuracy of the results as well as suggested cable are to remove. The full report may be printed.

When the setting is OFF, the FL-8A performs only a partial test, finding the distance of the short from the red probe and then pausing to display a report. You may press BACK to terminate the test, but the test's accuracy is, at this point, unknown. If you instead press NEXT, the FL-8A will then proceed to find the distance of the short from the blue probe. A summary screen showing the short's location from the red and blue probes, as well as the rated accuracy of the test and the suggested trim area, will display.

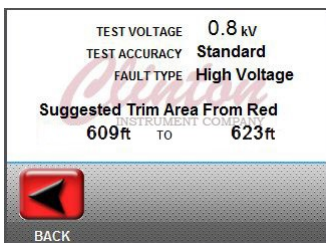

The default for Full Test is ON. Experienced operators working with a particular cable type are sometimes confident that a partial test is accurate and choose it to reduce test time. However, this is not recommended without the advice of a Clinton technician.

Lock Test Voltage

When this setting is ON, the Shorts Max Voltage setting cannot be changed at test time, although the voltage setting is displayed during the test.

Shorts Max Voltage

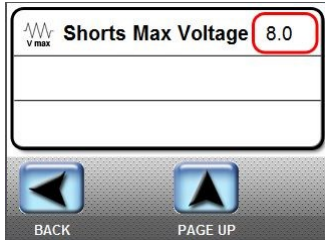

This setting is found on the second page of the Shorts Parameters settings. This is the maximum voltage that will be applied during the shorts test. An entry of 8.0 represents 8KV DC. To change the setting, press the existing value to view a keypad. Enter the new value, using the decimal point and press OK.

If this value is set too high, damage to the cable may result.

If the maximum voltage is set too low, a high voltage short may not arc and cannot be located.

Shorts Max Voltage can be changed at the time of test if Lock Test Voltage is OFF.

Opens Parameters

Access the Open Parameters settings from the Settings menu. They apply to opens tests that will be done. They are saved in memory even when the FL-8A is off. The default settings are usually optimum for opens testing. It is not advisable to change them, except the Auto Reverse Leads setting, without factory advice.

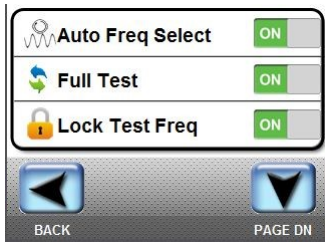

Auto Frequency Select

When this setting is ON, the FL-8A will automatically find the optimum frequency at which to test. When the setting is OFF, it will test at the Set Frequency, which may not give you correct results. The default setting is ON.

Full Test

When this setting is ON, the equipment will first locate the distance of the open from the blue probe, and then find its distance from the red probe. A summary screen showing the distance of the fault from each probe will display. The total of the two distances should equal the length of the test cable. By pressing MORE, the operator may view the rated accuracy of the results as well as a suggested cable area to remove. The full report may be printed.

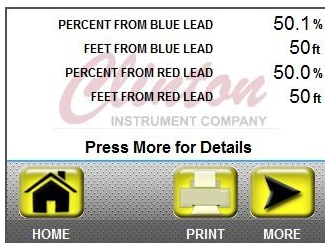

When the setting is OFF, the FL-8A performs only a partial test, finding the distance of the open from the blue probe, and then pausing to display a report. You may press BACK to terminate the test, but the test's accuracy is, at this point, unknown. If you instead press NEXT, the FL-8A will then proceed to find the distance of the short from the red probe. A summary screen showing the open's location from the red and blue probes, as well as the rated accuracy of the test and the suggested trim area, will display.

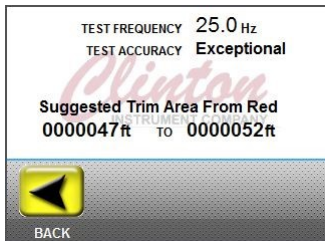

The default for Full Test is ON. Experienced operators working with a particular cable type are sometimes confident that a partial test is accurate and choose it to reduce test time. However, this is not recommended without the advice of a Clinton technician.

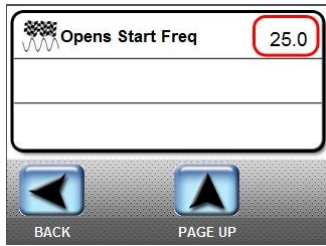

Lock Test Frequency

When this setting is ON, the FL-8A will not prompt the user to enter a test frequency before the Opens test. The default setting is ON.

Opens Start Frequency

This setting is found on Page 2 of the Opens Parameters menu. It is the frequency applied during the Opens test. The default setting is 23.0Hz. Do not change this frequency without factory advice.

Hi-Pot Parameters

Access Hi-Pot parameters from the Settings Menu.

Lock Hi-Pot Settings

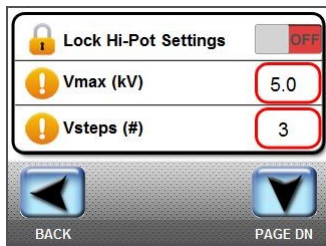

When Lock Hi-Pot Settings is OFF, the user can change the values that are entered in the Hi-Pot Parameters menu during a Hi-Pot test. When Lock Hi-Pot Settings is ON, the operator cannot change the parameters during the test. The default setting is OFF.

Vmax (kV)

This is the maximum Hi-Pot test voltage. The range is 1.0kV to 8.0 kV. This setting can be changed here to affect all Hi-Pot tests, or at the time of test if Lock Hi-Pot Settings is OFF.

Vsteps (#)

This is the number of steps the Hi-Pot test will take to get to Vmax (kV), the maximum Hi-Pot voltage. The number is between 2 and 20. This setting can be changed here to affect all Hi-Pot tests, or at the time of test if Lock Hi-Pot Settings is OFF.

Vramp Time (s)

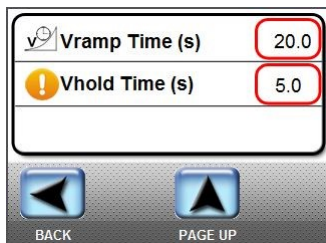

This setting is found on page 2 of the Hi-Pot parameters menu. This is the time, in seconds, up to 60 seconds, that the FL-8A will take to perform each Vstep to get to the preset maximum Hi-Pot voltage (Vmax (kV)). This setting can be changed here to affect all Hi-Pot tests, or at the time of test if Lock Hi-Pot Settings is OFF.

Vhold Time (s)

This is the time, in seconds, that the FL-8A will stay at Vmax (kV), the maximum test voltage, before the test ends. The maximum Vhold Time (s) is 60 seconds. This setting can be changed here to affect all Hi-Pot tests, or at the time of test if Lock Hi-Pot Settings is OFF.

Testing Large Cables with the FL-8A

If conductors are too large to insert into the probes, special attention must be paid to insure that proper connections are made. Poor connections can be dangerous to personnel. Additionally, the FL-8A graphics display may not function correctly due to excess electrical noise created by improper grounding.

Alligator clip assemblies similar to those shown in the photos below are highly recommended when cables to be tested are too large to fit properly in the probes. These items are available for purchase. Smaller cable sizes can use the enclosed 3 probe clip assemblies part number 92100. Larger cables may require part number 92113.

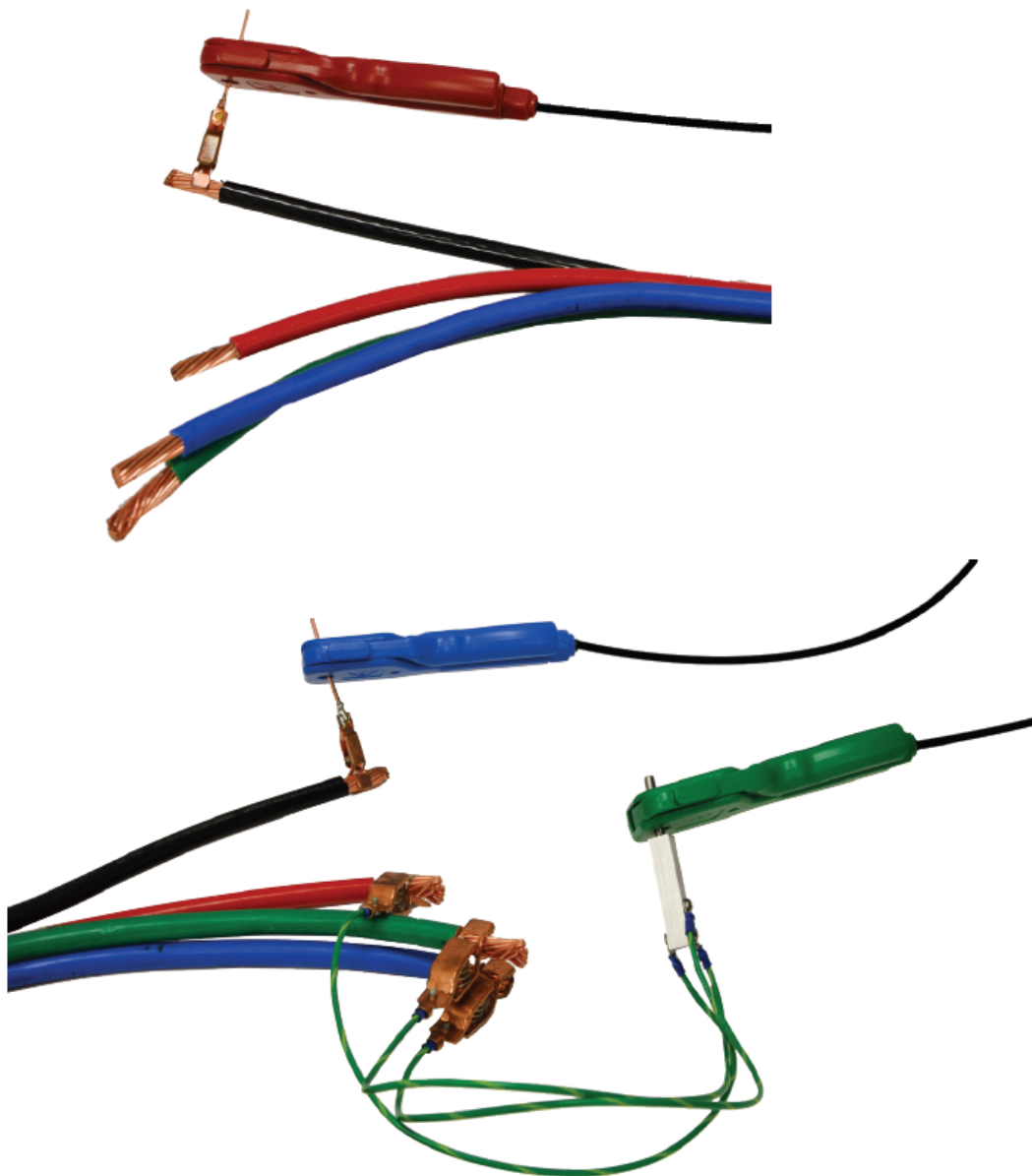

Performing a Shorts Test



Caution. DANGER!!!

It is imperative that only personnel trained in the dangers of high voltage operate this equipment. A stored charge in a test cable can kill! A charge can remain in a cable if the cable has not been properly discharged, even when it is no longer attached to the FL-8A. **Discharge all conductors of the test cable prior to connecting to the FL-8A to remove any stored charge from a previous operation. A stored charge in the cable can be lethal.**

Note: to determine the accuracy of the Shorts test that you can expect on your test product, please refer to the chart entitled, "Cable Loop Resistance Chart."

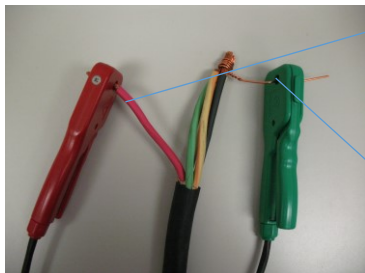

1. Review the Shorts Parameters settings that have been entered before proceeding with the test. They are found in the Settings menu.
2. Select the first conductor to be tested. Strip back by 1" and insert the exposed conductor into the red test probe. Be sure that insulation does not obstruct the connection between the metal in the probe and the exposed conductor. Strip the other end of the conductor and insert into the blue test probe.
3. **Ground all untested conductors.** On one end of the test cable, strip back all conductors not under test by 1" carefully bunch them together with the cable shield so that they make a good connection with one another and insert into the green ground probe. Be sure that insulation does not obstruct the connection between the metal in the probe and the exposed conductors. **Do not attempt to bypass this safety procedure. Failure to observe safety precautions can result in severe injury or death!**

NOTE: If conductors are too large to insert into the probes, see the section entitled, "Testing Large Cables with the FL-8A." It is critical that conductors be connected properly. Poor connections can be dangerous to personnel; additionally, the FL-8A graphics display may not function correctly due to noise.

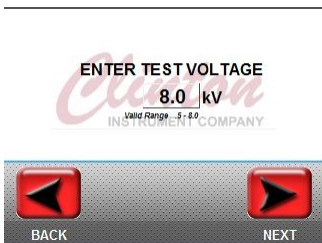

4. At the main menu, press the Shorts button to begin a test for high voltage shorts or metallic shorts. The screen will guide you through the test.
5. Enter the maximum test voltage. (If the Lock Test Voltage setting is ON, this screen will not be displayed.)



6. Enter the cable length. Press the displayed number to access the keypad and enter the test cable length. Press OK. The unit of measure entered previously in the Length UOM setting will appear. Press NEXT.

7. The yellow light will begin to flash, indicating that a test is in progress. If the green ground probe is connected as described in step 4, the touch screen will display, "Ground Probe Connected."

8. The touch screen will display, "Hold Safety Switches." Press the safety switches as directed.

9. The FL-8A touch screen will indicate test progress as it tries to locate the fault. The yellow test is in progress light will flash, and the red High Voltage light will go on, indicating that there is high voltage on the test cable.

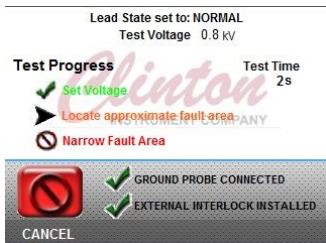

10. If the Full Test setting is OFF, the first test result screen, indicating the fault distance from the red probe, will appear. Press NEXT to continue the test or press HOME to exit the test.



If the Full Test setting is ON, the unit will proceed through both halves of the test, and a complete test summary report will appear. The fault distance from the blue probe plus the fault distance from the red probe should total the approximate length of the test cable.

11. If the test accuracy is Standard or better, a "More" button will display. Press More to view the test accuracy and suggested trim area.

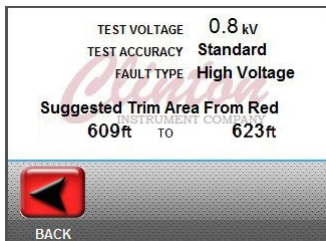

WARNING: Do not touch the red and blue probes or the test cable until the red light on the X3F goes OFF. The red light indicates that there is still a charge present on the test cable and the probes. Before handling the reel under test, wait at least 10 seconds, then discharge all conductors to ground. A stored charge in the cable can be lethal.

Performing an Open Tests

Caution.

It is imperative that only personnel trained in the dangers of high voltage operate this equipment. **A stored charge in a test cable can kill!** A charge can remain in a cable if the cable has not been properly discharged, even when it is no longer attached to the FL-8A. **Discharge all conductors of the test cable prior to connecting to the FL-8A Fault Locator to remove any stored charge from a previous operation. A stored charge in the cable can be lethal.**



Note: to determine the accuracy of the Opens test that you can expect on your test product, please refer to the chart entitled, "Cable Capacitance Chart."

1. Review the Opens Parameters settings that have been entered before proceeding with the test. They are found in the Settings menu.
2. Select the first conductor to be tested. Strip back by 1" and insert the exposed conductor into the red test probe. Be sure that insulation does not obstruct the connection between the metal in the probe and the exposed conductor. Strip the other end of the conductor and insert into the blue test probe.
3. **Ground all untested conductors.** On one end of the test cable, strip back all conductors not under test by 1", carefully bunch them together with the cable shield so that they make a good connection with one another and insert into the green ground probe. Be sure that insulation does not obstruct the connection between the metal in the probe and the exposed conductors.

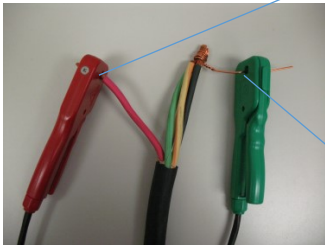

NOTE: If conductors are too large to insert into the probes, see the section entitled, "Testing Large Cables with the FL-8A." It is critical that conductors be connected properly. Poor connections can be dangerous to personnel. Additionally, the FL-8A graphics display may not function correctly due to noise.

4. At the main menu, press the Opens button to begin a test for opens. The screen will guide you through the test.
5. Enter the Test Frequency. If the Lock Test Frequency setting is ON, this screen will not be displayed. Under most circumstances, the Test Frequency should not be changed from the default.
6. Enter the cable length. Press the displayed number to access the keypad and enter the test cable length. Press OK. The unit of measure entered previously in the Length UOM setting will appear.



Press NEXT. Momentarily press the safety switches on the sides of the unit. The yellow light will begin to flash, indicating that a test is in progress. If the green ground probe has been connected as described in step 4, the touch screen will display, “Ground Probe Connected.” The yellow light will flash to alert that a test is in progress, and the FL-8A touch screen will indicate that the test has begun.



7. If the Full Test setting is OFF, the first test result screen, indicating the fault distance from the blue probe, will appear. Press NEXT to automatically reverse the leads and continue the test or press HOME to exit the test.
8. If the Full Test setting is ON, the unit will proceed through both halves of the test, and a complete test summary report will appear. The fault distance from the blue probe plus the fault distance from the red probe should total the length of the test cable.
9. If the test accuracy is Standard or better, a “More” button will display. Press More for Details to view the test accuracy and suggested trim area from the red probe.

Performing a Hi-Pot Test

Caution.

It is imperative that only personnel trained in the dangers of high voltage operate this equipment. **A stored charge in a test cable can kill!** A charge can remain in a cable if the cable has not been properly discharged, even when it is no longer attached to the FL-8A.



Discharge all conductors of the test cable prior to connecting to the FL-8A to remove any stored charge from a previous operation. A stored charge in the cable can be lethal.

Note: to determine the accuracy of the Hi-Pot test that you can expect on your test product, please refer to the chart entitled, "Cable Loop Resistance Chart."

1. Review the Hi-Pot Parameters settings that have been entered before proceeding with the test. They are found in the Settings menu.

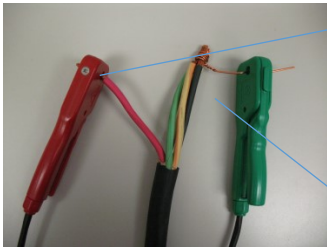

2. Select the first conductor to be tested. Strip back by 1" and insert the exposed conductor into the red test probe. Be sure that insulation does not obstruct the connection between the metal in the probe and the exposed conductor. Strip the other end of the conductor and insert into the blue test probe.

3. **Ground all untested conductors.** On one end of the test cable, strip back all conductors not under test by 1", carefully bunch them together with the cable shield so that they make a good connection with one another and insert into the green ground probe. Be sure that insulation does not obstruct the connection between the metal in the probe and the exposed conductors. **Do not attempt to bypass this safety procedure. Failure to observe safety precautions can result in severe injury or death!**

NOTE: If conductors are too large to insert into the probes, see the section entitled, "Testing Large Cables with the FL-8A." It is critical that conductors be connected properly. Poor connections can be dangerous to personnel. Additionally, the FL-8A graphics display may not function correctly due to noise.

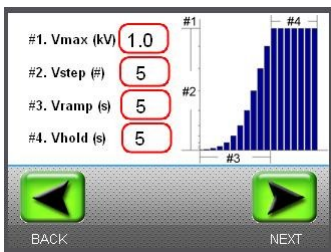

4. A descriptive graph of the settings that were entered in Hi-Pot Parameters will appear on the touch screen.

5. If Lock Hi-Pot Settings is OFF, all settings can be changed here, before the test begins. To change a setting, press on the setting value to access a keypad, enter the new value, and press OK. When all settings are correct, press NEXT.

If Lock Hi-Pot Settings is ON, settings cannot be changed. Press NEXT.

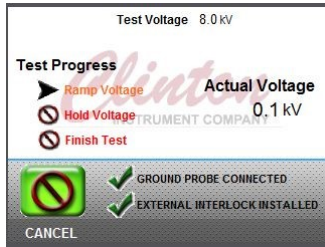

6. The touch screen will guide you through the hi-pot test. If the green ground probe is connected as described in step 4, the touch screen will display, “Ground Probe Connected.”

7. The touch screen will display, “Hold Safety Switches.” Press the safety switches as directed.



8. The FL-8A touch screen will indicate test progress as it tries to locate the fault. The yellow Test in Progress light will flash and the red High Voltage light will go on, indicating that there is high voltage on the test cable.

9. If the hi-pot test is successful, the touch screen will display, “Pass.” A “Pass” indicates that the tested conductors were able to withstand the preselected voltage for the preselected amount of time, without any arcing. If there is an arc condition, the touch screen will display, “Fail” and the voltage at which it failed.



WARNING: Do not touch the red and blue probes or the test cable until the red light goes OFF. The red light indicates that there is still a charge present on the test cable and the probes. Before handling the reel under test, wait at least 10 seconds, then discharge all conductors to ground. A stored charge in the cable can be lethal.

Calibration

An 8KV DC Voltage Divider and a DC multimeter are required to calibrate the FL-8A. Metering equipment **MUST** be able to withstand 8kVDC.



Caution.

It is imperative that only personnel trained in the dangers of high voltage operate this equipment. **A stored charge in a test cable can kill!** A charge can remain in a cable if the cable has not been properly discharged, even when it is no longer attached to the FL-8A.

Calibrate the FL-8A Output Voltage

The FL-8A Output Voltage is measured on the DC multimeter.

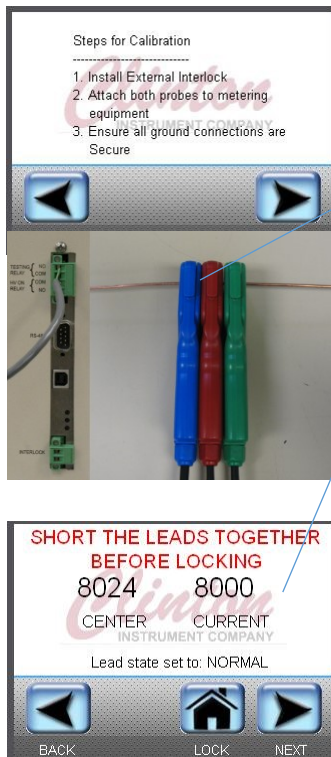

1. Press the Calibration button, which is found on the second page of the Settings menu.
2. As directed, short all three probes (red, blue, and green) together using a piece of copper or brass rod. Press NEXT.
3. The number displayed above CURRENT will be changing. Wait about 10 seconds and press the LOCK button. The CURRENT number will be saved to the CENTER number. The typical acceptable range is 12,000 to 15,000. Press NEXT.
4. Connect the shorted red and blue probes to the input of your DC multimeter.
5. Connect the green ground probe to earth ground. Check that the ground connection on the rear of the FL-8A is secure and connected to earth ground. Press NEXT.
6. The red high voltage present light on the FL-8A front panel will illuminate, indicating that there is high voltage on the red and blue probes.



DANGER! Do not touch the red and blue probes for the remainder of the calibration procedure, because they are charged.

7. As directed on the touch screen, use the DOWN ADJ and UP ADJ buttons so that the multimeter displays 1.0 kV (within 2% or +/- 20 volts). Press NEXT.

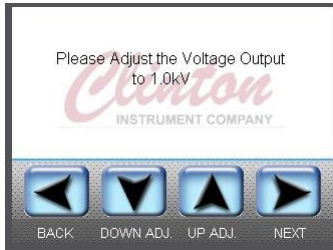

8. A new screen will appear. View the reading on the multimeter. If necessary, use the DOWN ADJ and UP ADJ buttons on the touch screen until the multimeter displays 6.0 kV (+/- 2% or 300 volts). If adjustments had to be made, press BACK to the previous screen.
9. Repeat steps 7 and 8 until the multimeter screen reads 6.0kV (+/- 2% or 300 volts) without further adjustment from the touch screen. Press NEXT.

Calibrate the FL-8A Voltage Reading

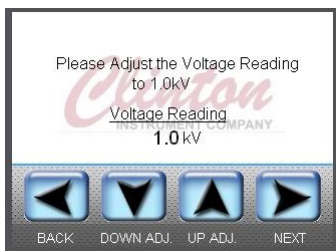

10. As directed on the touch screen, use the DOWN ADJ and UP ADJ buttons so that the Voltage Reading on the touch screen displays 1.0 kV. Press NEXT.
11. If the Voltage Reading on the touch screen is not 6.0kV, use the DOWN ADJ and UP ADJ buttons until the reading is 6.0kV. If adjustments had to be made, press BACK to the previous screen.
12. Repeat steps 1 and 2 until the Voltage Reading reads within 2% of 6.0 kV (+/- 300 volts) without further adjustment. Press NEXT.



13. To record a calibration point, press the Voltage Reading number to access a keypad. Enter a new Voltage Reading (a number from .5kV to 8.0kV) and press OK. Record the voltage output on the multimeter. A number within 2% of the Voltage Reading is within factory tolerance. Repeat as necessary.
14. Press NEXT. The calibration is complete. Press FINISH.

Maintenance

Fuses

The fuses in this equipment are not expected to fail in normal operation. Upon failure, they will reset themselves on the next power cycle.

Battery

The battery should be charged after every 8 hours of use, or earlier if the indicator is at 1 bar or below.

Charging should be done with the cover open and in an open area. Allow 15 hours for the battery to receive a full charge. Avoid charging the unit in areas with temperatures exceeding 110 degrees Fahrenheit.

If after 15 hours of charging, the battery indicates a level below 2 bars, contact the factory for a replacement. The factory will provide battery replacement procedure.

To retain battery capacity, charge every 10 days.

How to Use the 91785 FL Test Box

Description

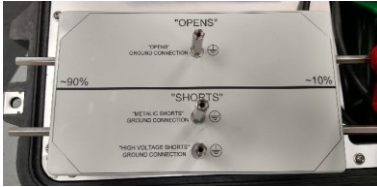

The 91785 FL Test Box is used to simulate three types of cable faults (Open, Metallic Short and High Voltage Short). The FL Test Box is useful in determining if the FL-20A or FL-8A is operating properly. Note the metal terminals, two on the left and right sides and three in the center.

The FL Test Box is used to simulate a cable fault at a point in the cable 90% from one side and 10% from the other. The Test Box is labeled 90% on the left side and 10% on the right. If the Blue Probe is placed on the 90% side, the result should be roughly 90% from the Blue side (10% from the Red side). The opposite result would be expected if the Red Probe were placed on the 90% side.

Type of Cable Faults

Of the three types of faults that can be simulated using the FL Test Box, the first is an Open, which simulates a break in a conductor of a cable. The second is a Metallic Short which simulates a conductor directly connected to another conductor in a cable. The last is a High Voltage Short, which simulates a conductor with a break in the insulation close to a ground shield, drain wire, or another conductor with a break in the insulation. In this instance, high voltage can arc from one conductor to another conductor or ground.

Testing with the FL Test Box

Select the appropriate test and connect the Red and Blue Probes to the appropriate terminals as directed. The Green ground probe always connects to the appropriate center terminal. The Probes should be placed over the terminals so that the terminals protrude on the other side.

Testing for Opens Accuracy

For Opens, connect the Blue and Red Probes to the upper terminals and the Green Probe to the center terminal as shown. Run the Opens test on the fault locator. We would expect a result where the fault is 90% (or within our claimed accuracy) from the blue side (10% from the Red side). These two results should total approximately 100%.



Testing for Metallic Shorts Accuracy



To perform a Metallic Shorts Test, connect the probes to the Shorts terminals as shown. Note the Green ground probe connects to the terminal labeled "METALLIC SHORTS". Run the Shorts Test on the cable fault locator at a voltage of at least 1kV. We expect a result where the fault is 90% (or within our margin of accuracy) from the blue side and 10% from the Red side. These two results should total approximately 100%.

Testing for High Voltage Shorts Accuracy

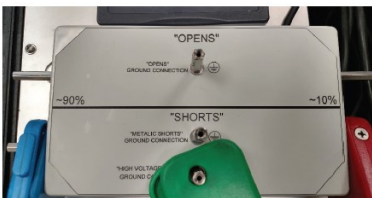

For running a High Voltage Shorts Test, connect the probes to the Shorts terminals as shown. Note the Green ground probe connects to the terminal labeled "HIGH VOLTAGE SHORTS". Run the Shorts Test on the cable fault locator at a voltage of at least 6kV. We would expect a result where the fault is 90% (or within our margin of accuracy) from the blue side and 10% from the Red side. These two results should total approximately 100%.

Cable Capacitance Chart

The accuracy of the FL-20A in Opens tests is limited by the test product's capacitance properties. Please consult the chart below to determine the results you can expect for your product.

	pF/Foot	50 Ft	100 Ft	250 Ft	500 Ft	1000 Ft	2000 Ft	5000 Ft	10000 Ft	25000 Ft	50000 Ft	100000 Ft
Better than .5%	5	0.25 nf	0.5 nf	1.25 nf	2.5 nf	5 nf	10 nf	25 nf	50 nf	125 nf	250 nf	500 n
Better than 1.0%	10	0.50 nf	1.0 nf	2.50 nf	5.0 nf	10 nf	20 nf	50 nf	100 nf	250 nf	500 nf	1000 n
Poor Results	20	1.00 nf	2.0 nf	5.00 nf	10.0 nf	20 nf	40 nf	100 nf	200 nf	500 nf	1000 nf	2000 n
	30	1.50 nf	3.0 nf	7.50 nf	15.0 nf	30 nf	60 nf	150 nf	300 nf	750 nf	1500 nf	3000 n
	40	2.00 nf	4.0 nf	10.00 nf	20.0 nf	40 nf	80 nf	200 nf	400 nf	1000 nf	2000 nf	4000 n
	50	2.50 nf	5.0 nf	12.50 nf	25.0 nf	50 nf	100 nf	250 nf	500 nf	1250 nf	2500 nf	5000 n
	60	3.00 nf	6.0 nf	15.00 nf	30.0 nf	60 nf	120 nf	300 nf	600 nf	1500 nf	3000 nf	6000 n
	70	3.50 nf	7.0 nf	17.50 nf	35.0 nf	70 nf	140 nf	350 nf	700 nf	1750 nf	3500 nf	7000 n
	80	4.00 nf	8.0 nf	20.00 nf	40.0 nf	80 nf	160 nf	400 nf	800 nf	2000 nf	4000 nf	8000 n
	90	4.50 nf	9.0 nf	22.50 nf	45.0 nf	90 nf	180 nf	450 nf	900 nf	2250 nf	4500 nf	9000 n
	100	5.00 nf	10.0 nf	25.00 nf	50.0 nf	100 nf	200 nf	500 nf	1000 nf	2500 nf	5000 nf	10000 n
	110	5.50 nf	11.0 nf	27.50 nf	55.0 nf	110 nf	220 nf	550 nf	1100 nf	2750 nf	5500 nf	11000 n
	120	6.00 nf	12.0 nf	30.00 nf	60.0 nf	120 nf	240 nf	600 nf	1200 nf	3000 nf	6000 nf	12000 n
	130	6.50 nf	13.0 nf	32.50 nf	65.0 nf	130 nf	260 nf	650 nf	1300 nf	3250 nf	6500 nf	13000 n
	140	7.00 nf	14.0 nf	35.00 nf	70.0 nf	140 nf	280 nf	700 nf	1400 nf	3500 nf	7000 nf	14000 n
	150	7.50 nf	15.0 nf	37.50 nf	75.0 nf	150 nf	300 nf	750 nf	1500 nf	3750 nf	7500 nf	15000 n
Cat 6	9	0.45 nf	0.9 nf	2.25 nf	4.5 nf	9 nf	18 nf	45 nf	90 nf	225 nf	450 nf	900 n
Cat 5	15	0.75 nf	1.5 nf	3.75 nf	7.5 nf	15 nf	30 nf	75 nf	150 nf	375 nf	750 nf	1500 n
Cat 3	19	0.95 nf	1.9 nf	4.75 nf	9.5 nf	19 nf	38 nf	95 nf	190 nf	475 nf	950 nf	1900 n
Coax	16.2	0.81 nf	1.6 nf	4.05 nf	8.1 nf	16.2 nf	32.4 nf	81 nf	162 nf	405 nf	810 nf	1620 n
Cntrl 26Ga wire to wire	27.3	1.37 nf	2.7 nf	6.83 nf	13.7 nf	27.3 nf	54.6 nf	136.5 nf	273 nf	682.5 nf	1365 nf	2730 n
Cntrl 16ga wire to wire	51.6	2.58 nf	5.2 nf	12.90 nf	25.8 nf	51.6 nf	103.2 nf	258 nf	516 nf	1290 nf	2580 nf	5160 n
Cntrl 26Ga wire to Shield	54	2.70 nf	5.4 nf	13.50 nf	27.0 nf	54 nf	108 nf	270 nf	540 nf	1350 nf	2700 nf	5400 n
Cntrl 16ga wire to Shield	102	5.10 nf	10.2 nf	25.50 nf	51.0 nf	102 nf	204 nf	510 nf	1020 nf	2550 nf	5100 nf	10200 n

Cable Loop Resistance Chart

The accuracy of the FL-20A in Shorts and Hipot tests is limited by the test product's cable loop resistance properties. Please consult the chart below to determine the results you can expect for your product.

Better than .5%

Better than 1.0%

Poor Results

AWG-Copper	Ohms/Foot	50	100	250	500	1000	2500	5000	7500	10000	25000	50000	75000	100000
1000 MCM	0.00011	0.0006	0.0011	0.0028	0.0055	0.0110	0.0275	0.0550	0.0825	0.1100	0.2750	0.5500	0.8250	1.1000
500 MCM	0.00021	0.0011	0.0021	0.0053	0.0105	0.0210	0.0525	0.1050	0.1575	0.2100	0.5250	1.0500	1.5750	2.1000
250 MCM	0.00042	0.0021	0.0042	0.0105	0.0210	0.0420	0.1050	0.2100	0.3150	0.4200	1.0500	2.1000	3.1500	4.2000
0000	0.00005	0.0025	0.0050	0.0125	0.0250	0.0500	0.1250	0.2500	0.3750	0.5000	1.2500	2.5000	3.7500	5.0000
0000	0.00063	0.0032	0.0063	0.0158	0.0315	0.0630	0.1575	0.3150	0.4725	0.6300	1.5750	3.1500	4.7250	6.3000
00	0.00008	0.0040	0.0080	0.0200	0.0400	0.0800	0.2000	0.4000	0.6000	0.8000	2.0000	4.0000	6.0000	8.0000
0	0.0001	0.0050	0.0100	0.0250	0.0500	0.1000	0.2500	0.5000	0.7500	1.0000	2.5000	5.0000	7.5000	10.0000
1	0.000127	0.0064	0.0127	0.0318	0.0635	0.1270	0.3175	0.6350	0.9525	1.2700	3.1750	6.3500	9.5250	12.7000
2	0.00016	0.0080	0.0160	0.0400	0.0800	0.1600	0.4000	0.8000	1.2000	1.6000	4.0000	8.0000	12.0000	16.0000
4	0.0002485	0.0124	0.0249	0.0621	0.1243	0.2485	0.6213	1.2425	1.8638	2.4850	6.2125	12.4250	18.6375	24.8500
6	0.0003951	0.0198	0.0395	0.0988	0.1976	0.3951	0.9878	1.9755	2.9633	3.9510	9.8775	19.7550	29.6325	39.5100
8	0.0006282	0.0314	0.0628	0.1571	0.3141	0.6282	1.5705	3.1410	4.7115	6.2820	15.7050	31.4100	47.1150	62.8200
10	0.0009989	0.0499	0.0999	0.2497	0.4995	0.9989	2.4973	4.9945	7.4918	9.9890	24.9725	49.9450	74.9175	99.8900
12	0.001588	0.0794	0.1588	0.3970	0.7940	1.5880	3.9700	7.9400	11.9100	15.8800	39.7000	79.4000	119.1000	158.8000
14	0.002525	0.1263	0.2525	0.6313	1.2625	2.5250	6.3125	12.6250	18.9375	25.2500	63.1250	126.2500	189.3750	252.5000
16	0.00402	0.2010	0.4020	1.0050	2.0100	4.0200	10.0500	20.1000	30.1500	40.2000	100.5000	201.0000	301.5000	402.0000
18	0.00639	0.3195	0.6390	1.5975	3.1950	6.3900	15.9750	31.9500	47.9250	63.9000	159.7500	319.5000	479.2500	639.0000
20	0.01015	0.5075	1.0150	2.5375	5.0750	10.1500	25.3750	50.7500	76.1250	101.5000	253.7500	507.5000	761.2500	1015.0000
22	0.01614	0.8070	1.6140	4.0350	8.0700	16.1400	40.3500	80.7000	121.0500	161.4000	403.5000	807.0000	1210.5000	1614.0000
24	0.02567	1.2835	2.5670	6.4175	12.8350	25.6700	64.1750	128.3500	192.5250	256.7000	641.7500	1283.5000	1925.2500	2567.0000
26	0.04081	2.0405	4.0810	10.2025	20.4050	40.8100	102.0250	204.0500	306.0750	408.1000	1020.2500	2040.5000	3060.7500	4081.0000
28	0.0649	3.2450	6.4900	16.2250	32.4500	64.9000	162.2500	324.5000	486.7500	649.0000	1622.5000	3245.0000	4867.5000	6490.0000
30	0.1032	5.1600	10.3200	25.8000	51.6000	103.2000	258.0000	516.0000	774.0000	1032.0000	2580.0000	5160.0000	7740.0000	10320.0000
AWG Aluminum														
6	0.000661	0.0331	0.0661	0.1653	0.3305	0.6610	1.6525	3.3050	4.9575	6.6100	16.5250	33.0500	49.5750	66.1000
4	0.000416	0.0208	0.0416	0.1040	0.2080	0.4160	1.0400	2.0800	3.1200	4.1600	10.4000	20.8000	31.2000	41.6000
2	0.000261	0.0131	0.0261	0.0653	0.1305	0.2610	0.6525	1.3050	1.9575	2.6100	6.5250	13.0500	19.5750	26.1000
1	0.000207	0.0104	0.0207	0.0518	0.1035	0.2070	0.5175	1.0350	1.5525	2.0700	5.1750	10.3500	15.5250	20.7000
0	0.000185	0.0083	0.0165	0.0413	0.0825	0.1650	0.4125	0.8250	1.2375	1.6500	4.1250	8.2500	12.3750	16.5000
00	0.00013	0.0065	0.0130	0.0325	0.0650	0.1300	0.3250	0.6500	0.9750	1.3000	3.2500	6.5000	9.7500	13.0000
000	0.000103	0.0052	0.0103	0.0258	0.0515	0.1030	0.2575	0.5150	0.7725	1.0300	2.5750	5.1500	7.7250	10.3000
0000	0.000082	0.0041	0.0082	0.0205	0.0410	0.0820	0.2050	0.4100	0.6150	0.8200	2.0500	4.1000	6.1500	8.2000
250 MCM	0.000069	0.0035	0.0069	0.0173	0.0345	0.0690	0.1725	0.3450	0.5175	0.6900	1.7250	3.4500	5.1750	6.9000
500 MCM	0.000035	0.0018	0.0035	0.0088	0.0175	0.0350	0.0875	0.1750	0.2625	0.3500	0.8750	1.7500	2.6250	3.5000
1000 MCM	0.000017	0.0009	0.0017	0.0043	0.0085	0.0170	0.0425	0.0850	0.1275	0.1700	0.4250	0.8500	1.2750	1.7000

Troubleshooting

- An error displays: “The safety switches were let go.”
The two safety switches were released during the test. Press the CANCEL button to return to the main menu and begin the test again. Hold in the safety switches for the duration of the test.
- During a shorts test, an error displays: “Inadequate arc rate.”
The voltage may be too low to cause an arc to short from the test conductor to ground. Increase the voltage.
There may be no fault in the product. Run a Hi-Pot test to confirm the presence of a fault.
- During a shorts test, an error displays: “Accuracy: Low.”
When a test takes a very long time and the report screen says your accuracy is low, you may have a multiple fault condition. The FL-8A will find the first fault so it can be cut out and the cable retested to locate a second short. This setting is not recommended for low loop resistance products, because it can give false positives.
- An error displays: “Cannot Find Open.” If you run the test without attaching the red and blue probes, the error message, “Cannot Find Open” will be displayed.
- FL-8A cannot find faults.
In a situation where there are multiple direct or high voltage shorts, you may not locate any of them.
- The ground probe is connected, but it is not detected.
Insure that both contacts of the ground probe make a good connection to the ground wire.
- Test accuracy is rated Low.
Insure that both contacts of each probe are making a good connection.
Insure that the ground probe is connected to all wires that are not being tested.
The test voltage may be too low.
- The FL-8A will not power up.
The battery may require recharging. Try plugging the FL-8A into an AC socket.

Replacement Parts

Note: Printed circuit boards are carefully constructed and calibrated at the factory. Components are not supplied for field repair of boards. Please return faulty circuit boards to the factory for repair and calibration.

Part Number	Description
92245P8I	Touchscreen Display Color, Programmed
91526	Power Supply 24V DC 200W
91175	Power Supply 70W
91497C	Stepper Motor 4-Wire
91549	Timing Belt
91498	Potentiometer 1K 10-Turn 5W
91494	PC Board Assembly High Voltage Bridge
91496	PC Board Assembly Low Voltage Main
91499	Power Supply 20kV 125W
91627C	Rotary Solenoid 10v DC w/Connector
02606	Fuse 2 amp 5x20mm
91610	Transformer 20kV DC 115/230v
91609	Test Lead Assembly 10'
91609-20	Test Lead Assembly 20'
92100	Probe Clip Assembly (for connecting larger cables)
92113	Probe Clip Assembly (for connecting largest cables)

Optional Accessories

Part Number	Description
GND-SP	Ground Probe Assembly
Printer Thermal Receipt	Thermal Printer
90901	Printer Paper, roll

Electric Shock Considerations for Electric Vehicle Charging Systems

By Walter Skuggevig, Research Department, Melville, reprinted courtesy of Underwriters Laboratories Inc. This technical paper was presented in December 1993 at the National Conference on Electric Vehicle Infrastructure, sponsored by the Electric Power Research Institute, Arizona Public Service, Salt River Project, and the Electric Vehicle Association of the Americas.

Electric Shock- What is It?

Before electric shock can be addressed with a view toward prevention, the term and the concept should be explained. There are a number of physiological effects that can occur from electric current through the human body. From the standpoint of electrical safety, critical physiological effects are startle reaction - related to perception, muscle tetanization, ventricular fibrillation and burns. Each effect occurs at a different or increased level of electric current.

Perception and Startle Reaction

A few microamperes available from a conductive surface can be felt as a tingling sensation if the conductive surface is lightly rubbed or tapped with the finger. These small currents are harmless, but if perceived by a consumer, the "electric" sensations might appear sinister. The tingling sensation can raise suspicions, although perhaps not warranted, about the safety of a product.

A 60-Hz sinusoidal current over 0.5 mA RMS can cause an involuntary startle reaction, particularly in women. The current itself is harmless, but the uncontrolled movement of a startled person can cause secondary accidents including spills and falls. The American National Standards Institute (ANSI) document C101-1992 specifies 0.5 mA as the general limit for 60-Hz leakage current from appliances.

At frequencies lower and higher than power distribution frequencies, higher current is necessary to produce the same level of sensation. For direct current, a limit of 2 mA is often used. Continuously flowing direct current may not produce a particularly strong sensation, but a sudden change in the current caused either by making or breaking the circuit can produce a strong, momentary sensation. The higher the DC current, the stronger the sensation when the current is started or interrupted. At frequencies of approximately 1kHz and higher, it can be estimated that the threshold of startle reaction is approximately equal to 1 mA per kHz of frequency. For example, if a specific level of reaction from current at 1 kHz occurs at 1 mA, then a similar level of reaction would occur from 10 mA at 10 kHz. The same level of reaction would occur from 100 mA at 100 kHz, and so on. Leakage current measuring instruments, such as those specified in ANSI C101-1992, take into account the effect of high frequencies on the body. These

instruments produce readings that are “frequency-weighted,” and indicate the level of possible physiological effect. The readings correspond to the current magnitude in mA only at low frequencies such as 60 Hz.

Muscle Tetanization

Electric current over 5 mA at 60 Hz can cause muscle tetanization. Tetanization is defined as the state of continuous contraction of a muscle undergoing a series of rapidly repeated stimuli. A person with tetanized muscles may be unable to let go of a conductive part, may be immobilized (frozen), or may be unable to breathe while the current flows. Tetanization lasts as long as the current flows. When the current stops, the effect stops, and the muscle returns to normal function. However, the effect can be fatal if breathing stops long enough. If immersed in water, an immobilized person could drown. In a manner comparable to perception, tetanization occurs at a higher current threshold for DC and for higher frequencies.

Ventricular Fibrillation

Ventricular fibrillation is a disorder involving disorganized arrhythmic motion of the heart that affects blood circulation. Unlike muscle tetanization, ventricular fibrillation can be triggered by a short-duration burst of current of sufficient magnitude. Ventricular fibrillation is not spontaneously reversible in humans and, if not treated quickly with special defibrillating equipment, will continue until the person dies (within a few minutes) from loss of circulation of the blood.

The magnitude of limb-to-limb current sufficient to cause ventricular fibrillation is greater than that which would cause muscle tetanization. Therefore, limits for continuous current (e.g., lasting over five seconds or so) are usually based on muscle tetanization considerations.

A general limit that has been used by UL for a number of product categories including ground-fault circuit-interrupters is described as $I = 20 T^{-0.7}$ for bursts of 60-Hz current down to 20.9 milliseconds. I is in RMS mA calculated over the duration of the current; T is the current duration in seconds. For durations between four and 20.9 milliseconds, the current is limited to 300 mA. Below four milliseconds, the current is limited by $I = 6.3 T^{-0.7}$. These equations represent curves drawn under threshold fibrillating data points from laboratory experimental work conducted with animal subjects.

For durations shorter than a tenth of a second, the limits for AC and DC current are the same. For current lasting only a few milliseconds, a narrow piece of a 60-Hz sinusoid is not substantially different from a rectangular DC pulse. For durations over a tenth of a second, direct current has higher limits. Animal test data indicates that for long duration exposures to combinations of AC and DC, the parameter of current that is most related to the threshold of ventricular fibrillation is the peak-to-peak value of the current, if the

DC component is low enough so that there is reversal of the current each cycle. In fact, as long as the current reverses, the presence of a DC component is not significant with regard to the ventricular fibrillation threshold. If the DC component is high enough to preclude reversal of the current of each cycle of the AC component, then the occurrence of ventricular fibrillation is more related to the peak value of the composite waveform. In no case should the peak of the composite continuous waveform of AC and DC exceed the peak-to-peak value of the AC component at its maximum permitted value. For example, at one second duration or longer, if the ventricular fibrillation limit for an AC sinusoidal current is 20 mA RMS, the corresponding limit for a direct current would be 40, which is 56.6 mA. If the duration is between 0.1 and 1.0 second, the equation $I = 56.6 T^{-0.25}$ describes a suitable limit for DC current.

Burns

Prevention of electrical burns is a very complex subject. There are many variables that are difficult to control or estimate. A limit of 70 mA RMS, independent of frequency, has been used in a number of standards to address burns. At this current level, it is not likely that a severe burn injury would occur that would involve an appreciable volume of skin tissue. This limit becomes important at frequencies over several kHz, because limits addressing other hazards would not automatically prevent burns.

There are a number of commonly used techniques to reduce the risk of electric shock. Each has attributes that render it more effective for certain applications. In some cases, a combination of techniques may be the best method to reduce the risk of electric shock to an acceptable level. The protective mechanism should be compatible with the nature of the product, its ratings, habits and behavior of the people using the product, and the environment in which the product is used.

Grounding

The principle of equipment grounding can be described as follows: all accessible conductive parts are connected together and to earth by a network of low-impedance conductors to create an equipotential environment. Two important considerations are the reliability of the connections and the impedance of the conductors at the frequencies involved. Ground monitors that interrupt current and/or sound an alarm can enhance reliability. Low impedance in the grounding conductor circuitry is important in order to maintain low voltage to ground on accessible conductive parts during a fault before an interrupting device shuts off the circuit.

Double Insulation

Double insulation enhances the reliability of the electrical insulation of a product to reduce the likelihood of insulation breakdown that could cause an electric shock. Each part of a double-insulation system should be independent and must be fully capable of

acting as the sole insulation. If one insulation fails, the other must have all of the required attributes to prevent electric shock. It is important that the two parts of the double-insulation system are as truly independent as feasible. Both insulations should not be vulnerable to the same act (e.g., a drop on a hard surface or immersion in water) or deteriorating agent (e.g., high temperature or over-surface contamination).

Ground Fault Circuit Interrupter

A ground-fault circuit-interrupter (GFCI) monitors the difference in the current flowing between the power conductors serving a load. If the difference exceeds a predetermined level, it is assumed that the difference in current could be flowing through a person's body, and the GFCI rapidly trips. The speed of interruption is, by design, fast enough to avert ventricular fibrillation. A typical Class A GFCI trips in approximately one cycle of 60 Hz, and is intended for use on circuits that have no more than 150 volts to ground. Circuits with more than 150 volts to ground could cause higher body currents during a groundfault that would require a considerably shorter trip time to avert ventricular fibrillation. Class A GFCIs used in the United States for electric shock protection have a differential current trip rating of 5 mA. As such, these devices protect consumers from ventricular fibrillation, as well as muscle tetanization, which prevents them from breaking contact.

Many GFCIs are rated for a 15- or 20-ampere, 60-Hz load. Many GFCIs have not been designed or tested for use on circuits involving larger loads, higher frequencies, nonsinusoidal waveshapes and DC components. New designs of GFCIs may be needed for use on some of the electric vehicle charging circuits.

A GFCI discerns load current from possible electric shock current by where the current flows. Current flowing both to and from the load through the differential transformer is considered by the device to be acceptable. Current greater than the trip rating that flow outside the differential transformer is not acceptable. If a load is configured so that a current carrier is connected to an accessible part, shock current might be able to flow and not be discerned by a GFCI as being different from ordinary load current. For example, if one side of the circuit is connected to the vehicle chassis, then shock current between an accessible energized part and the vehicle chassis would appear to the GFCI as load current. A GFCI would not be able to protect against this type of fault.

If the system contains more than one source of voltage that can be hazardous, a single GFCI may not be able to protect against electric shock. Both sources need to be considered by the protection scheme.

Shielding

Shielding can be used to limit voltages that can appear on accessible conductive parts during fault conditions when products generate high voltages internally. A properly connected shield will prevent voltage on the accessible conductive parts from exceeding line voltage during fault conditions. This can help a GFCI function within its design capabilities and protect people effectively from electric shock from

products that would otherwise demand a faster trip speed of the GFCI for shock protection.

Fire hazards resulting from short-circuits involving the shield and internal high-voltage supplies can be controlled by overcurrent devices, temperature-sensitive devices and similar products.

Polarization

Polarization is a form of shielding. If the physical layout of a product is such that parts connected to one side of the line of a grounded system are more likely to be touched or fault to accessible parts, then the line connections should be such that the grounded side of the line is connected to those more exposed parts. This can involve the use of plugs and connectors that permit mating with only one polarity.

Interlocks and “Smart” Circuits

Interlocks and “smart” circuits can be used to keep potentially hazardous parts de-energized unless specific safety conditions are satisfied. Some of these “safety” conditions include specific covers that must be closed, specific connectors that must be fully mated with the proper receptacles, or a power source that “handshakes” with the intended load, and nothing else but the intended load.

“Smart” circuits may involve waveshaping and recognition networks that permit current of recognizable traits to flow, but that also de-energize the circuit if the current is not shaped by the load in precisely the expected way. The addition of a human body in the circuit would add a load of characteristics that are different from expected, and the source would be rapidly de-energized.

The protective mechanisms that should be required may be different for each product design. In general, the system of protection against electric shock should consist of one or more of those mechanisms that will effectively reduce the risk of electric shock to an acceptable level. The choices should be appropriate, feasible and consistent with today’s technology.

The National Electrical Code contains requirements for the installation of electrical products, but product safety standards cover the details and complexities of the design and construction of the various products, including which protective mechanisms or combinations of protective mechanisms are considered satisfactory to meet the need for protection against electric shock.

Manufacturers of electric vehicles, charging ports and associated equipment need to consider this information as they design the electric cars of the future. If the new vehicle designs include the appropriate protection equipment to prevent potentially dangerous physiological effects, then electric vehicles will provide a modern, safe and environmentally friendly mode of transportation.

Warranty

The information contained in this document is subject to change without notice. The Clinton Instrument Company makes no warranty of any kind with regard to this material, including, but not limited to, the implied warranties or merchantability and fitness for a particular purpose.

The Clinton Instrument Company shall not be liable for errors contained herein or for incidental damages in connection with the furnishing, performance, or use of this material.

We warrant to the original purchaser that the equipment described herein is free from defects in materials and workmanship for a period of one year from the date of invoice, our obligation under this warranty being limited to repair or replacement of the defective parts. This warranty does not apply to fuses, lamps, or any normally expendable parts. Any part appearing to have defects in material or workmanship, upon our examination only and as determined by us, and providing the equipment has not been subject to abuse, misuse, or alteration, will be repaired or replaced at no charge for materials and labor, either upon receipt of the defective part or equipment, transportation charges prepaid, at our plant or at the equipment location, as selected by us. No parts or equipment shall be returned without our prior permission. Any parts replaced under this warranty shall be warranted until the expiration date of the original warranty.

The warranties herein are in lieu of all other warranties, expressed or implied, and of all other obligations or liabilities on our part concerning this equipment.